

<b>G.V.W.R.</b>	59,800#	<b>Axle</b>	(2) 22,500# Dual Wheel Air Brake - Oil Bath
<b>G.A.W.R. (Ea. Axle)</b>	18,160#	<b>Supension</b>	44K Adjustable
<b>Coupler</b>	SAE 2" Kingpin	<b>Tire</b>	ST215/75 R-17.5 Load Range H
<b>Jack</b>	Adjustable 4 Position Landing Legs	<b>Wheel</b>	6.75 x 17.5, 10 Bolt Budd
<b>Neck</b>	16" 31# I-Beam	<b>Floor</b>	2" Nominal Oak (S4S)
<b>Frame</b>	16" 31# I-Beam	<b>Lights</b>	LED D.O.T. Stop, Tail, Turn & Clearance
<b>Crossmembers</b>	10" 12# I-Beam	<b>Elec. Plug</b>	7-Way Semi Style Socket
<b>Side Rails</b>	12" Channel	<b>Finish (Prep)</b>	Steel is Cleaned to Ensure a Professional Smooth Finish.
		<b>FINISH</b>	Superior Quality Finish is Applied for a Highly Decorative and Protective Finish.

## Standard Features

- Modular Sealed Wiring Harness w/Junction Box
- Safety Reflective Marker Tape
- 102" Wide
- Low Profile Bed
- 12" Channel Side Rails
- 2 Side Bed Steps
- Oak Flooring
- 8 - 1" O.D. D-Rings
- Heavy Duty Oil Bath w/12-1/4" x 7-1/2" Air Brakes, Including Automatic Slack Adjusters & Spring Brakes on Both Axles
- Anti-Skid Brake System on Front Axle
- 3' Dove Tail w/5' Double Hinged Spring Assist Ramps
- Grommet Mount Sealed LED Lighting

## Description

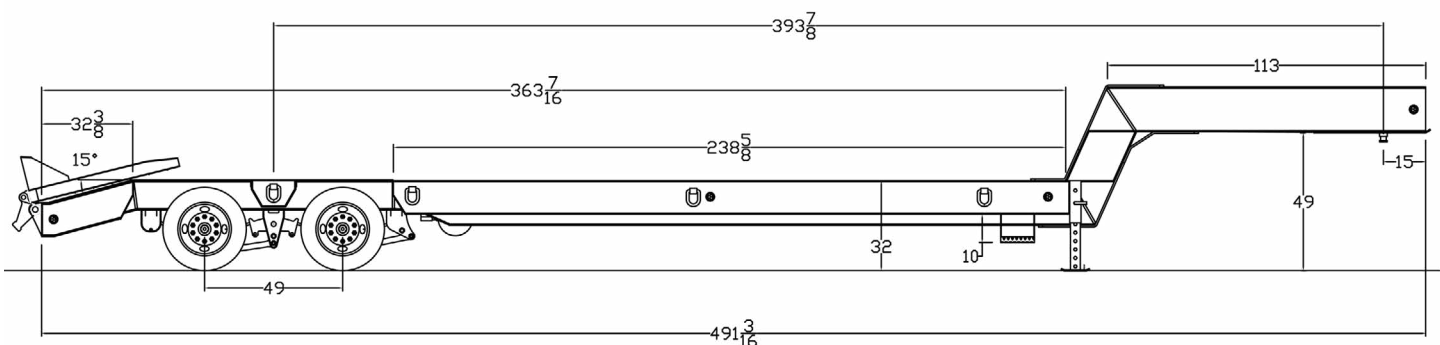

# 5XGL Lowboy Heavy Equipment Transport ●



Shown with full width neck option and plate over tires

Model	Weight*	Description
*5XGL-20+3	11,600#	102" x 20' Equipment Transport

\*Weights shown are for base models without options and are estimates only

## Optional Equipment

Category	Description
JACKS	Dual Two Speed Landing Gear Jacks (50K)
TIRE/WHEEL	Spare Tire (ST215/75 R-17.5 LR-H Dual)
BRAKES	ABS on 2nd Axle
BODY	Full Width Neck
BODY	Plate Over The Tires (Raises bed height by 2")
CARGO CONTROL	1" D-Ring (Each)

**\* Trailer is subject to Federal Excise Tax**